

CRANE SCALES

10kg to 50ton

(30, 40, 50 ton)

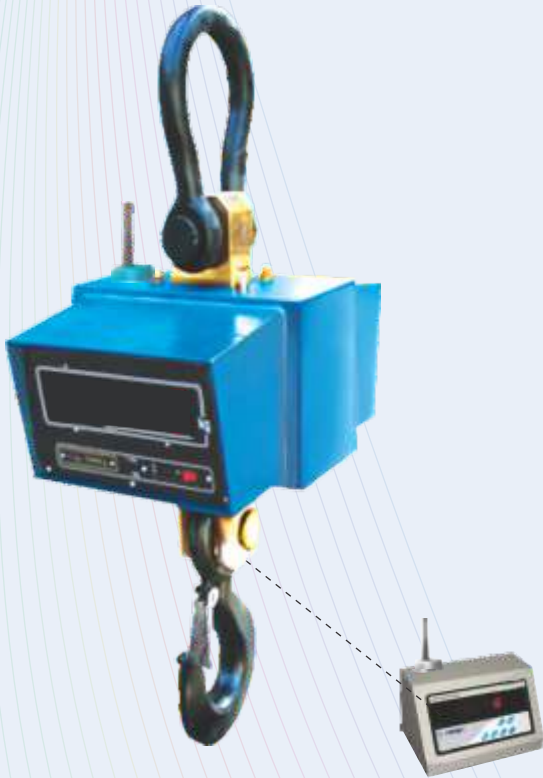

CRANE SCALES with Wireless Indicator

Features :

- ♦ Wireless transmission maximum operating distance between the Scale and Indicator is 50 mtr.
- ♦ All specifications are same as standard crane scales (CCS) except there is no display on the scale and there is no RF keyboard.
- ♦ Power indication LED on the scale.
- ♦ Battery & charger for the loadcell & transmitter inside the scale.
- ♦ Weight display on the desktop indicator along with controls.
- ♦ RS-232 interface in the indicator (Optional).
- ♦ Indicator with optional battery backup.
- ♦ Date & time entry facility.
- ♦ Storage of weights in memory upto 100 samples.
- ♦ Display hold facility.

Common Specifications :

MODELS	CAPACITY	ACCURACY	DIMENSION				E x F	NET WT. (Kg)
			H	A	B	C		
CCS-30T10K	30 ton	10Kg	1110	160	260	90	500x310	156
CCS-40T20K	40 ton	20Kg	1200	180	220	110	440x410	235
CCS-50T20K	50 ton	20Kg	1310	200	270	110	440x410	280

Taring Range : Up to full capacity
Response time : 5 seconds
Power Req : 90-250V, 50/60Hz, 10 Watt
Operating Temperature : 10 to 45 deg C

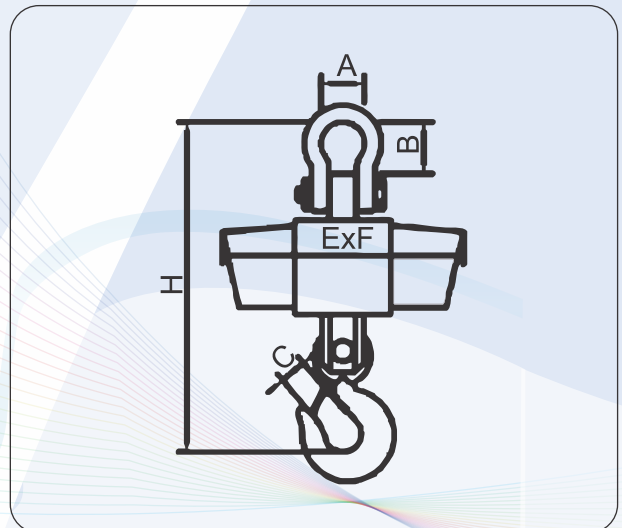

All Specifications and designs are subject to change for improvement.



CONTECH[®]
Instruments Ltd.
AN ISO 9001,14001 & 45001 COMPANY
Where innovation never stops.....

301, Punit Indl. Premises, Turbhe Naka, Navi Mumbai - 400 705.
Tel. : +91 22 6139 3000 (100 lines)
E-mail : sales@contechindia.in
Website: www.contechindia.com

FACTORY / NABL LAB



Plot No. EL-221 TTC Indl. Area, MIDC (Electronic Zone),
Mhape, Navi Mumbai - 400 710.