

PLATFORM SCALES

5g to 1ton

Features :

- ♦ Indicator housed in a sturdy metal enclosure.
- ♦ Bright LED display.
- ♦ Multiple functions: Parts counting, accumulation, net/gross.
- ♦ Standard bi-directional RS-232 interface.
- ♦ Overload & shock load protection.
- ♦ Bright Red LED display.
- ♦ High bright green LED display (optional).
- ♦ Battery backup (optional).
- ♦ Rechargeable sealed maintenance free battery.

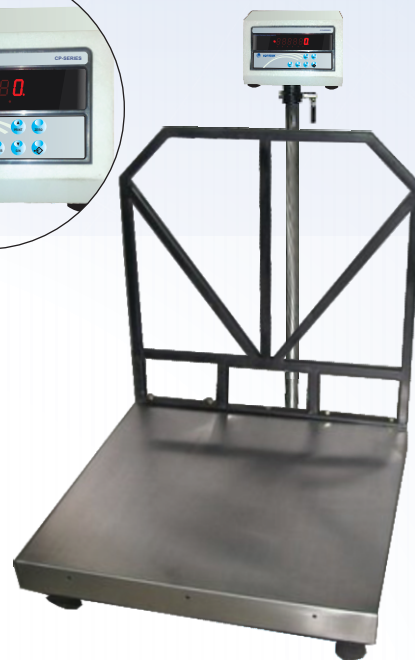

Taring Range : Up to full capacity
 Response time : 3-5 secs
 Power Req : 90-250V, 50/60Hz, 10 Watt
 Operating Temperature : 10 to 45 deg C

Specifications :

Models	CP-50K0.2	CP-60K0.5	CP-75K5	CP-100k1	CP-100K10	CP-200K5	CP-200K20	CP-300K5	CP-300K20	CP-450K10	CP-600K50	CP-1T100
Capacity	50kg	60kg	75kg	100kg	100kg	200kg	200kg	300kg	300kg	450kh	600kg	1ton
Readability	0.2g	0.5g	5g	1g	10g	5g	20g	5g	20g	10g	50g	100g
Platform Sizes(mm)	350x350	400x400	400x400	400x400	450x500	600x600	600x600	600x600	600x600	600x600	600x600	1000x1000

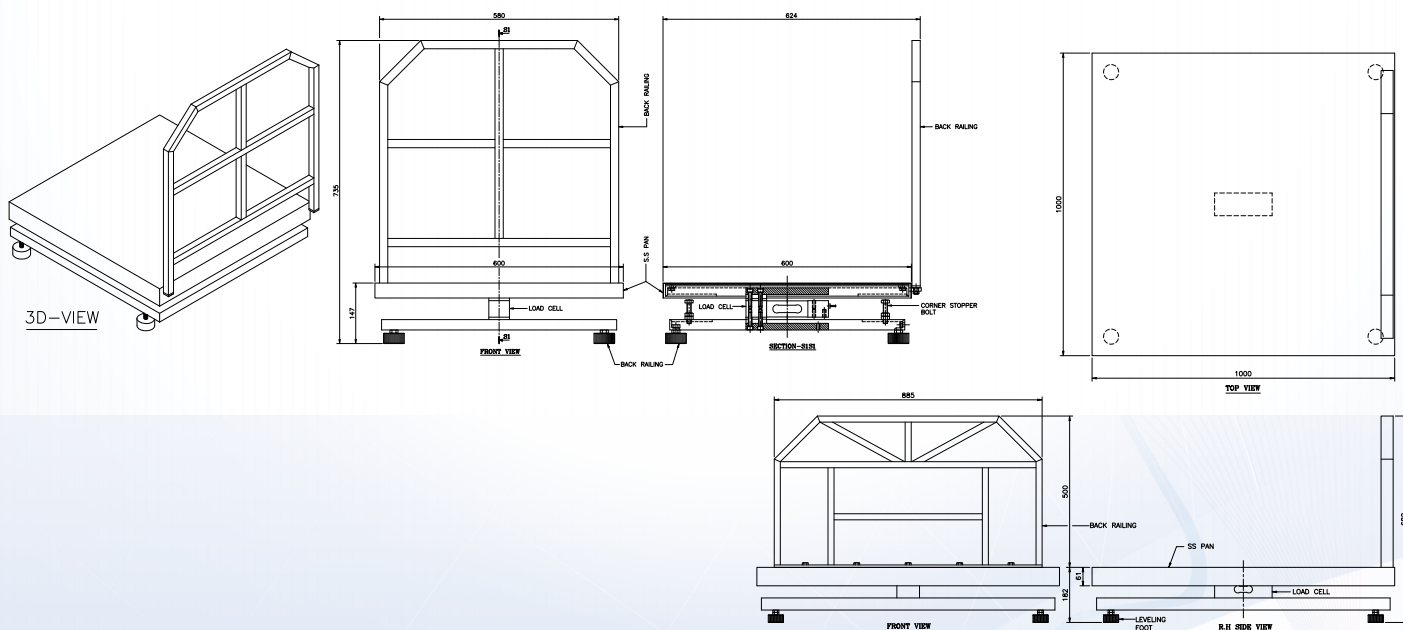

All Specifications and designs are subject to change for improvement.



CONTECH[®]
Instruments Ltd.
 AN ISO 9001,14001 & OHSAS 18001 COMPANY
Where innovation never stops.....

301, Punit Indl. Premises, Turbhe Naka, Navi Mumbai - 400 705.
 Tel. :+91 22 6139 3000 (100 lines)
 Fax :+91 22 2761 8421
 E-mail : info@contechindia.in / sales@contechindia.in
 Website: www.contechindia.com

